

POS.	CODE	DESCRIPTION
1	TABLE 1	ASSEMBLY WORKING BENCH
2	TABLE 2	ASSEMBLY SLIDE
3	TABLE 3	ASSEMBLY VERTICAL CLAMP
4	TABLE 4	ASSEMBLY COMMAND HANDLE
5	TABLE 5	ASSEMBLY V-NAILS MAGAZINE
6	TABLE 6	FLOOR STAND

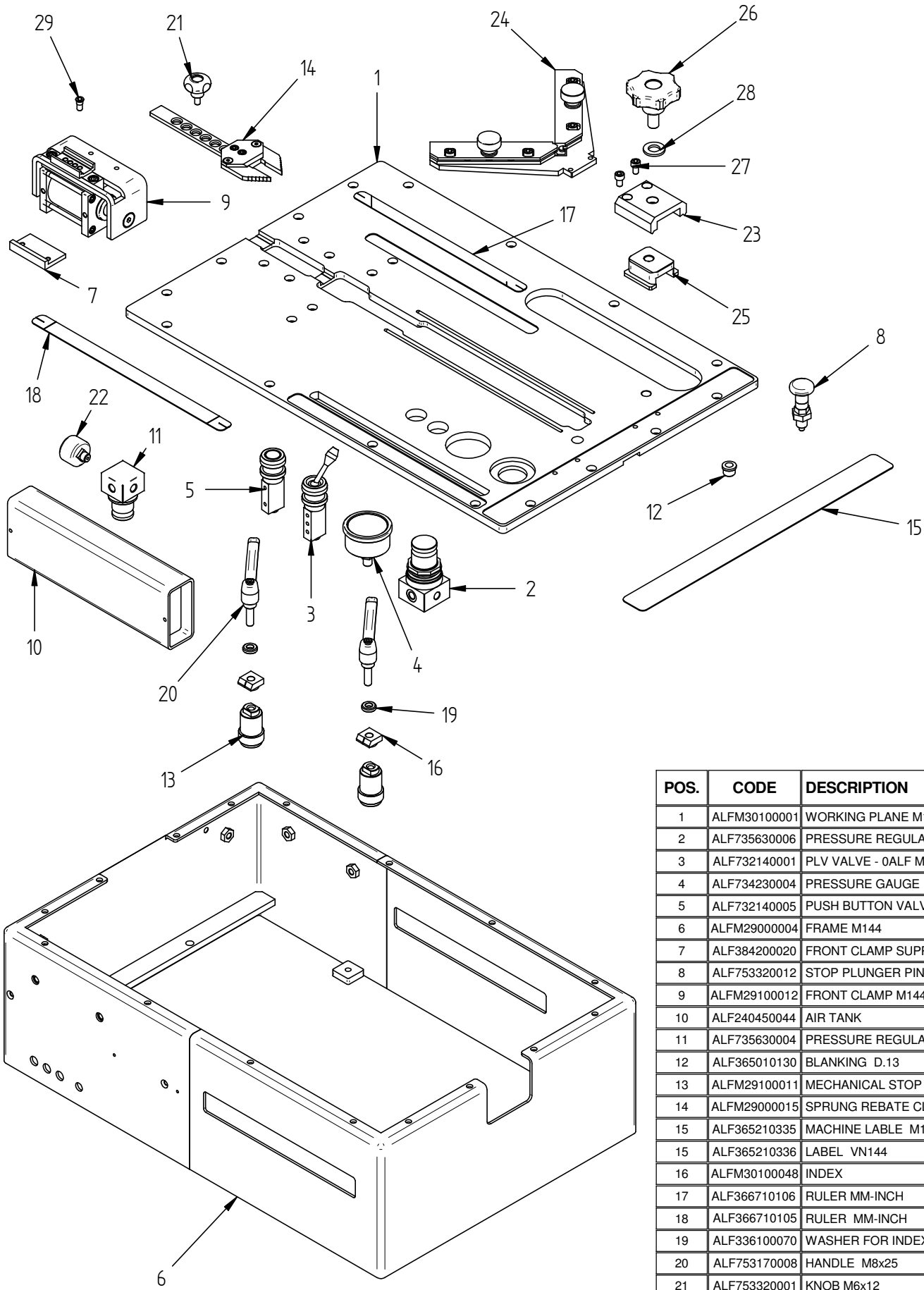

POS.	CODE	DESCRIPTION
1	ALFM30100001	WORKING PLANE M144
2	ALF735630006	PRESSURE REGULATOR BIT 1/8
3	ALF732140001	PLV VALVE - 0ALF M5
4	ALF734230004	PRESSURE GAUGE 0-10 BAR 1/8
5	ALF732140005	PUSH BUTTON VALVE
6	ALFM290000004	FRAME M144
7	ALF384200020	FRONT CLAMP SUPPORT
8	ALF753320012	STOP PLUNGER PIN
9	ALFM291000012	FRONT CLAMP M144
10	ALF240450044	AIR TANK
11	ALF735630004	PRESSURE REGULATOR 0-4 1/8
12	ALF365010130	BLANKING D.13
13	ALFM291000011	MECHANICAL STOP
14	ALFM290000015	SPRUNG REBATE CLAMP
15	ALF365210335	MACHINE LABLE M144
15	ALF365210336	LABEL VN144
16	ALFM301000048	INDEX
17	ALF366710106	RULER MM-INCH
18	ALF366710105	RULER MM-INCH
19	ALF336100070	WASHER FOR INDEX
20	ALF753170008	HANDLE M8x25
21	ALF753320001	KNOB M6x12
22	ALF734230002	PRESSURE GAUGE 0-4 BAR 1/8
23	ALFM301000009	FENCE SUPPORT
24	ALFM291000004	TWO KNOBS FENCE M144
25	ALFM301000010	SLIDE FOR FENCE LOCK
26	ALFM301000080	HANDWHEEL M12x22
27	ALF710100072	SCREW TCEI M6x10
28	ALF718100006	WASHER M12
29	ALF366210030	SPECIAL SCREW FOR SPRUNG REBATE CLAMP

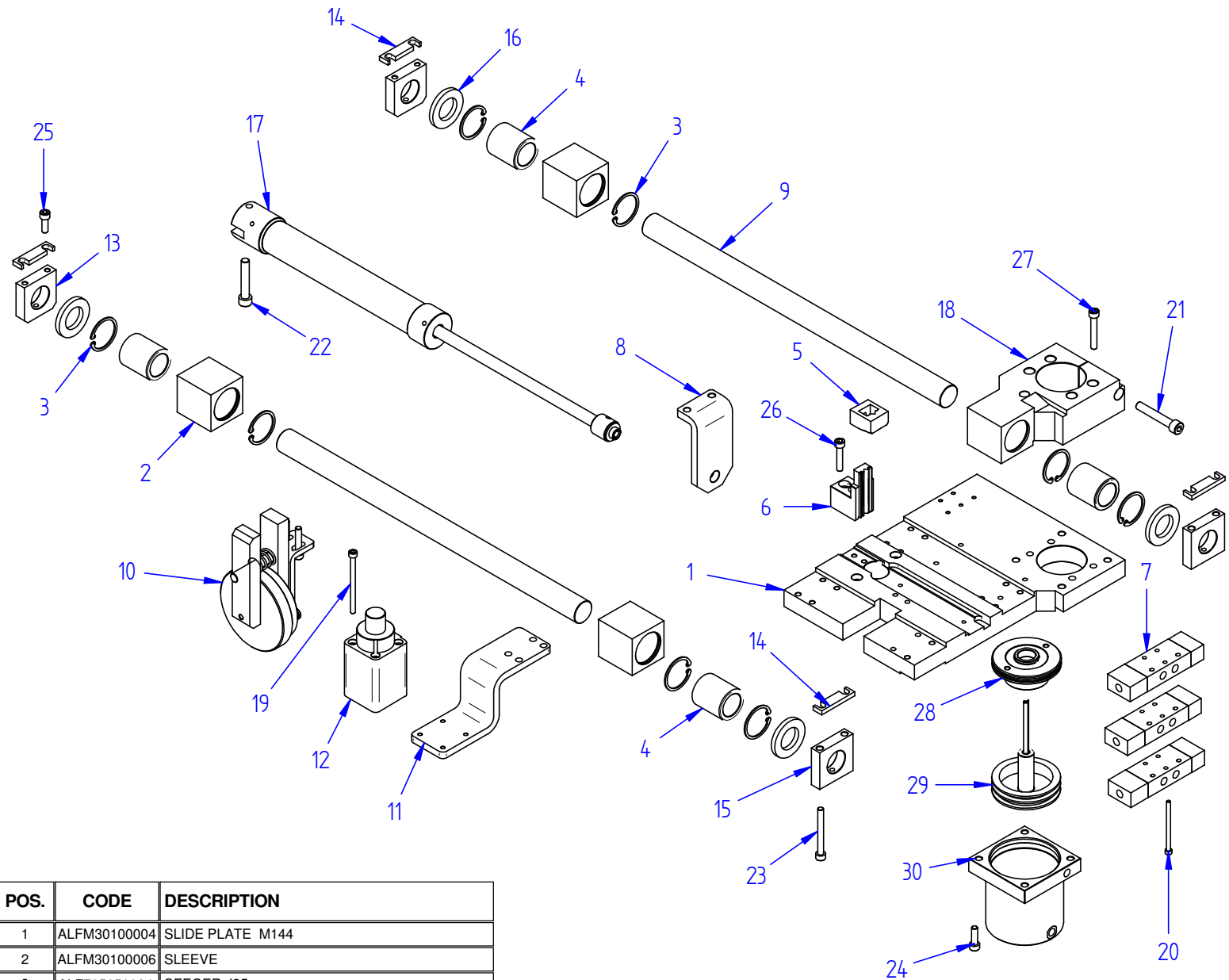

POS.	CODE	DESCRIPTION
1	ALFM30100004	SLIDE PLATE M144
2	ALFM30100006	SLEEVE
3	ALF705050024	SEEGER I35
4	ALF740550084	BUSHING KH2540
5	ALF394950570	V-NAIL CLAW HEAD MC
6	ALFM30100011	L BLOCK SUPPORT M144
7	ALF732440003	VALVE
8	ALFM30100039	BALANCE CYLINDER SUPPORT M144
9	ALF334000490	ROD MC
10	ALFM22000004	BRAKE M144
11	ALFM30000009	SUPPORT FOR STOPPER CYLINDER
12	ALF753750017	STOPPER CYLINDER
13	ALFM30100002	FRONT ROD SUPPORT
14	ALFM30100003	SPACER
15	ALFM30100005	REAR ROD SUPPORT
16	ALFM30100012	RING
17	ALFM29100008	BALANCE CYLINDER M144
18	ALFM30100076	ROD SUPPORT
19	ALF710100061	SCREW TCEI M5x70
20	ALF710100015	SCREWTCEI M4x60
21	ALF710100120	SCREWTCEI M8x50
22	ALF710100119	SCREWTCEI M8x45
23	ALF710100147	SCREWTCEI M6x55
24	ALF710100093	SCREW TCEI M6x20
25	ALF710100076	SCREW TCEI M6x18
26	ALF710100080	SCREW TCEI M6x30
27	ALF710100082	SCREW TCEI M6x40
28	ALF352400010	HEAD
29	ALFM29100022	DRIVER BLADE COMPLETE M144
30	ALF352200260	CYLINDER

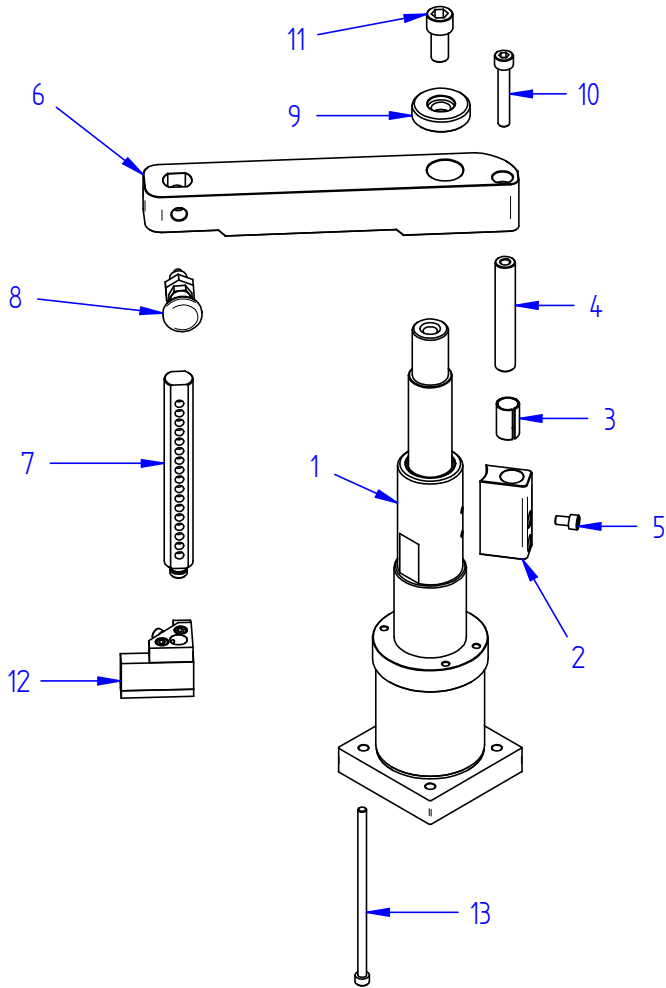

POS.	CODE	DESCRIPTION
1	ALFM22100002	COLUMN COMPLETE M144
2	ALFM30100038	ARM STOPPER
3	ALF753420016	BUSHING D14 L25
4	ALFM30100044	ANTI-ROTATION PIN
5	ALF710100072	SCREW TCEI M6x10
6	ALFM30100018	ARM M144
7	ALF334000100	VERTICAL CLAMP ROD
8	ALF753320010	PLUNGER PIN
9	ALF336100120	WASHER
10	ALF710100120	SCREW TCEI M8x50
11	ALF710100190	SCREW TCEI M12x25
12	ALF242230050	SQUARE MECHANICAL PAD
13	ALF710100067	SCREW TCEI M6x140

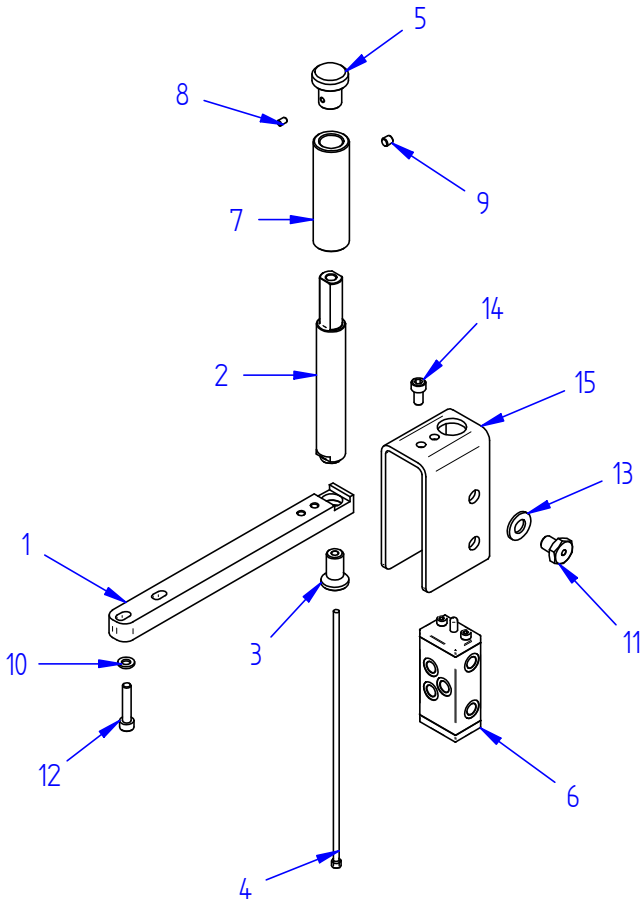

POS.	CODE	DESCRIPTION
1	ALFM30100017	HANDLE LEVER
2	ALFM30100051	PIN LEVER
3	ALF366210020	LEVER SCREW
4	ALF331500060	PUSH BUTTON ROD COMPLETE
5	ALF363710020	PUSH BUTTON
6	ALF732290001	PUSHBUTTON VALVE
7	ALF336500090	PUSH BUTTON BUSH
8	ALF714300063	SET-SCREW M4x6
9	ALF714300015	SET-SCREW M6x6
10	ALF718100003	WASHER M6
11	ALFM30100053	VALVE SUPPORT SCREW
12	ALF710100080	SCREW TCEI M6x30
13	ALF718100005	WASHER M10
14	ALF710100073	SCREW TCEI M6x12
15	ALFM29000005	VALVE PROTECTION

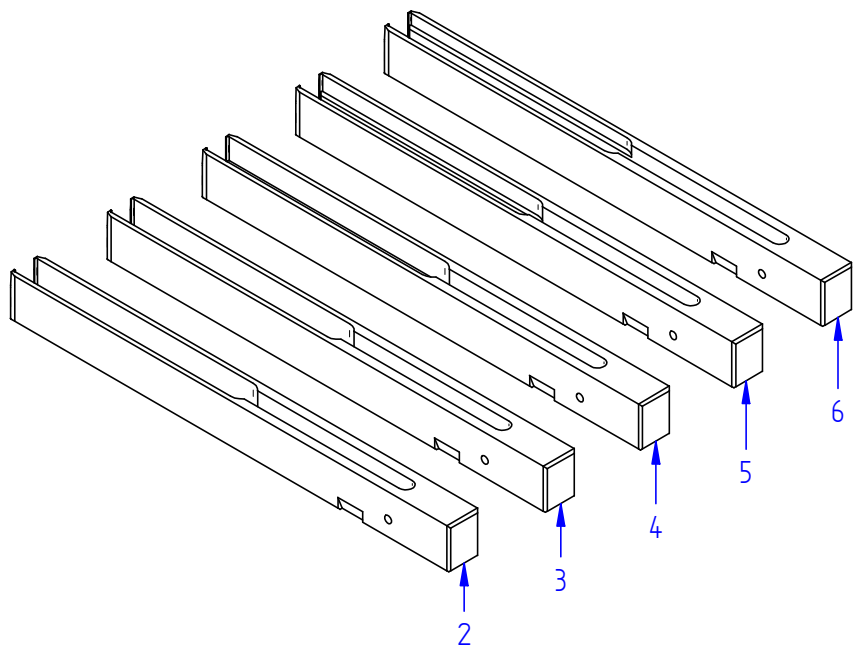
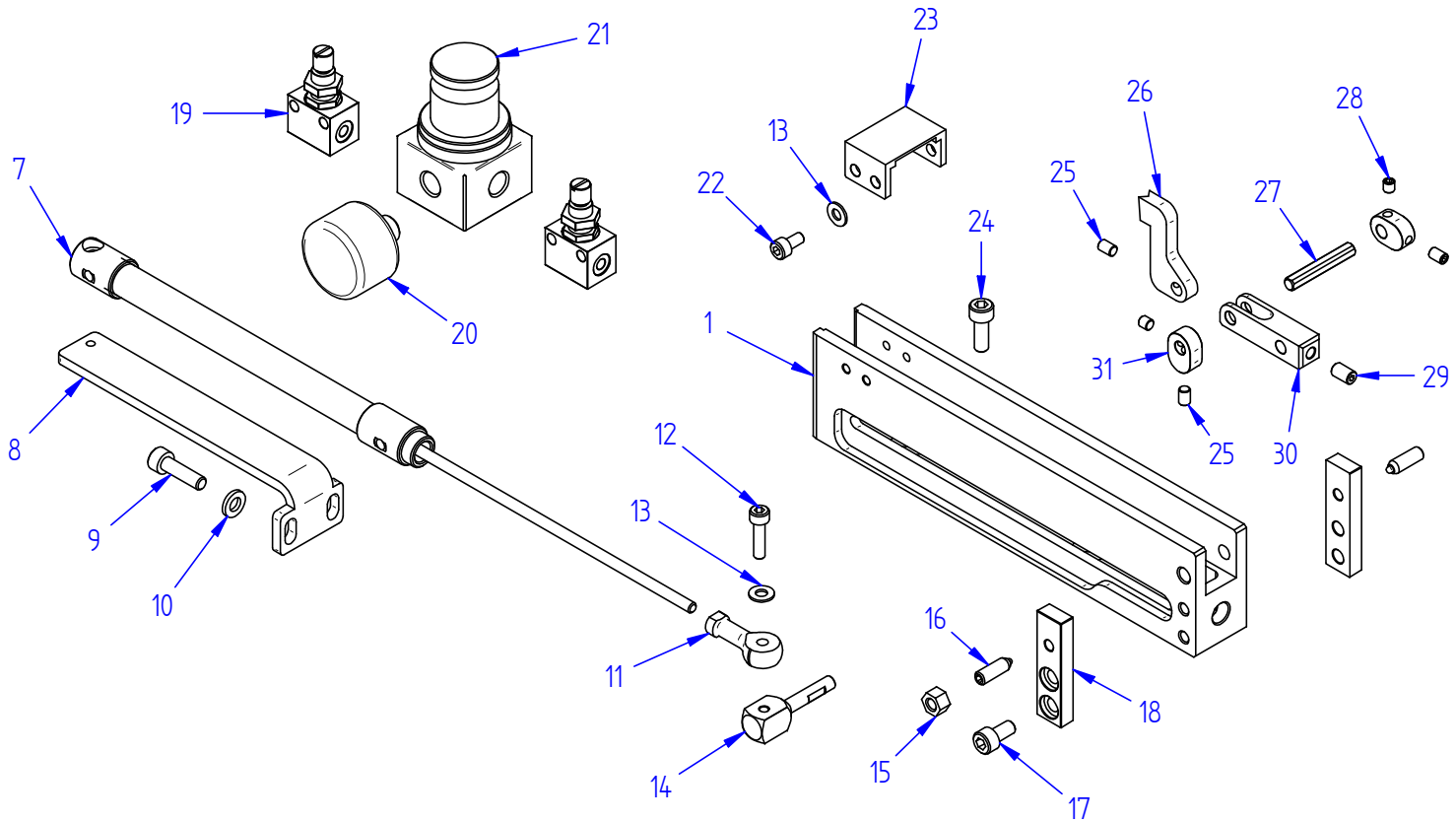

POS.	CODE	DESCRIPTION
1	ALFM30100054	MAGAZINE
2	ALFM30100055	V-NAILS STICK SUPPORT H15
3	ALFM30100056	V-NAILS STICK SUPPORT H12
4	ALFM30100057	V-NAILS STICK SUPPORT H10
5	ALFM30100058	V-NAILS STICK SUPPORT H7
6	ALFM30100059	V-NAILS STICK SUPPORT H5
7	ALFM29100020	CLAW PUSHER CYLINDER M144
8	ALFM30000003	CLAW PUSHER SUPPORT M144
9	ALF710100046	SCREW TCEI M5x18
10	ALF718100002	WASHER M5
11	ALF753320014	BALL HEAD RF4
12	ALF710100006	SCREW TCEI M4x16
13	ALF718100001	WASHER M4
14	ALFM30100065	PIN DRIVER
15	ALF715650002	BOLT M5
16	ALF753320013	LOCK M5
17	ALF710100042	SCREW TCEI M5x10
18	ALFM30100070	LOCK SUPPORT
19	ALF732630003	FLOW REGULATOR
20	ALF734230002	PRESSURE GAUGE 0-4 BAR 1/8
21	ALF735630004	PRESSURE REGULATOR 0-4 1/8
22	ALF710100002	SCREW TCEI M4x8
23	ALFM30100082	COVER
24	ALF710100044	SCREW TCEI M5x14
25	ALF714300063	SET SCREW M4x6
26	ALFM30100066	TOOTH
27	ALFM30100079	PIN
28	ALF714300003	SET SCREW M4x4
29	ALF714300073	SER SCREW M5x8
30	ALFM30100062	SLIDE
31	ALFM30100078	CAM

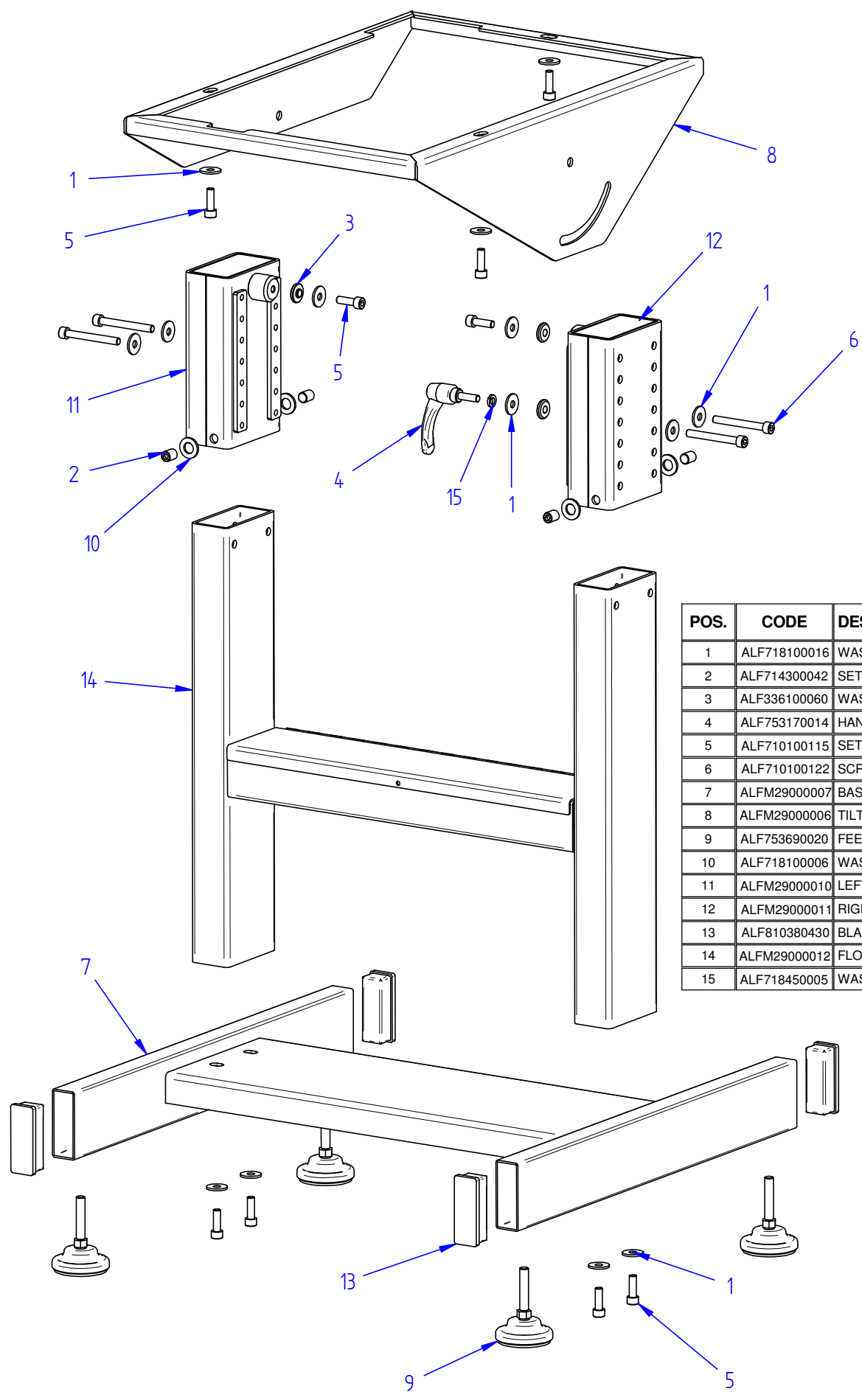

POS.	CODE	DESCRIPTION
1	ALF718100016	WASHER 8x24
2	ALF714300042	SET SCREW M12x1,25x16
3	ALF336100060	WASHER
4	ALF753170014	HANDLE M8x25
5	ALF710100115	SET SCREW TCEI M8x25
6	ALF710100122	SCREW TCEI M8x70
7	ALFM29000007	BASEMENT
8	ALFM29000006	TILTING SUPPORT
9	ALF753690020	FEET M10x50
10	ALF718100006	WASHER M12
11	ALFM29000010	LEFT HIGH ADJ SUPPORT
12	ALFM29000011	RIGHT HIGH ADJ SUPPORT
13	ALF810380430	BLANKING 80x30
14	ALFM29000012	FLOOR STAND LEGS
15	ALF718450005	WASHER M8

